

# Homework 6

---

Course Title: Digital Signal Processing I (Spring 2020)

Course Number: ECE53800

Instructor: Dr. Li Tan

Author: **Zhankun Luo**

Chapter 7:

Problems 7.1, 7.2 (b), 7.5 (b), 7.6 (b), 7.7, 7.8, 7.9, 7.10, 7.11, 7.15, 7.19, 7.20

MATLAB Project 7.36

Advanced Problem 7.38

## Problems

### Problems 7.1

Design a three-tap FIR lowpass filter with a cutoff frequency of 1500 Hz and a sampling rate of 8000 Hz using

1. Rectangular window function
2. Hamming window function.

Determine the transfer function and difference equation of the designed FIR system, and compute and plot the magnitude frequency response for  $\Omega=0, \pi/4, \pi/2, 3\pi/4,$  and  $\pi$  (rad).

### solution

$$2 \times M + 1 = 3 \Rightarrow M = 1$$

$$\Omega_c = 2\pi \times \frac{f_c}{f_s} = 1.1781$$

$$h(n) = \begin{cases} \frac{\Omega_c}{\pi} & \text{for } n = 0 \\ \frac{\sin(\Omega_c n)}{n\pi} & \text{for } n \neq 0 \quad -M \leq n \leq M \end{cases}$$

$h(-M) \sim h(M)$  are  $[0.2941, 0.375, 0.2941]$

### 1. Rectangular window function

$$w_{\text{rec}}(n) = 1, -M \leq n \leq M$$

$$h_w(n) = h(n) \cdot w(n) = [0.2941, 0.375, 0.2941]$$

Transfer function

$$H(z) = 0.2941 + 0.375z^{-1} + 0.2941z^{-2}$$

Difference equation

$$y(n] = 0.2941x(n) + 0.375x(n - 1) + 0.2941x(n - 2)$$

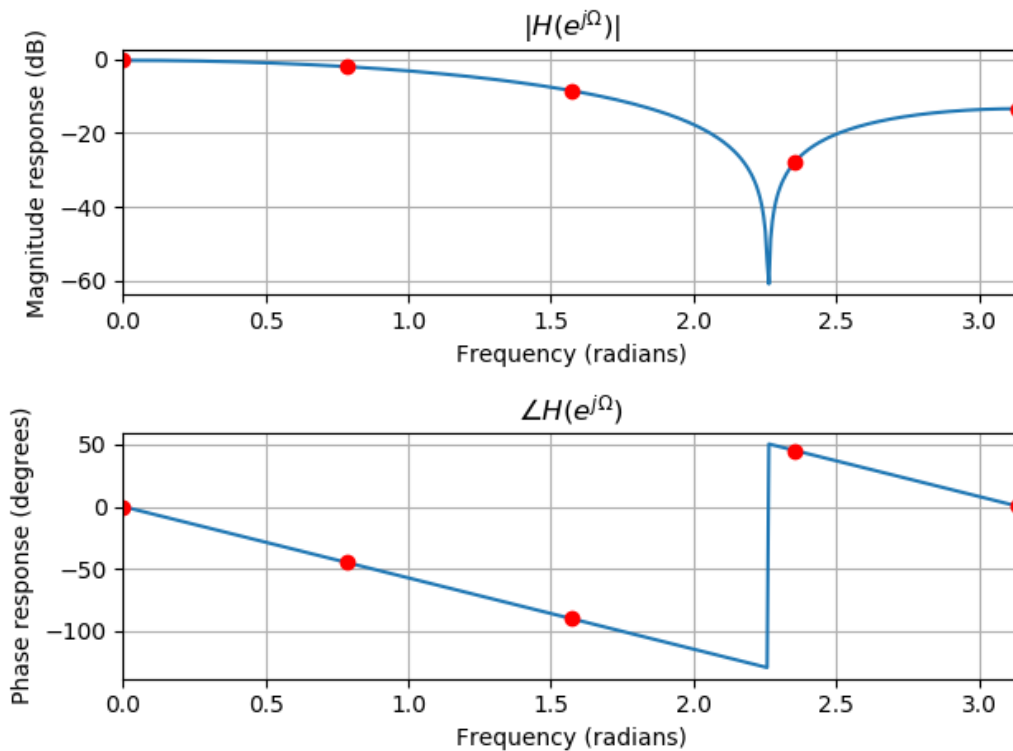

### 2. Hamming window function

$$w_{\text{ham}}(n) = 0.54 + 0.46 \cos\left(\frac{n\pi}{M}\right), -M \leq n \leq M$$

$$h_w(n) = h(n) \cdot w(n) = [0.0235, 0.375, 0.0235]$$

Transfer function

$$H(z) = 0.0235 + 0.375z^{-1} + 0.0235z^{-2}$$

Difference equation

$$y(n] = 0.0235x(n) + 0.375x(n - 1) + 0.0235x(n - 2)$$

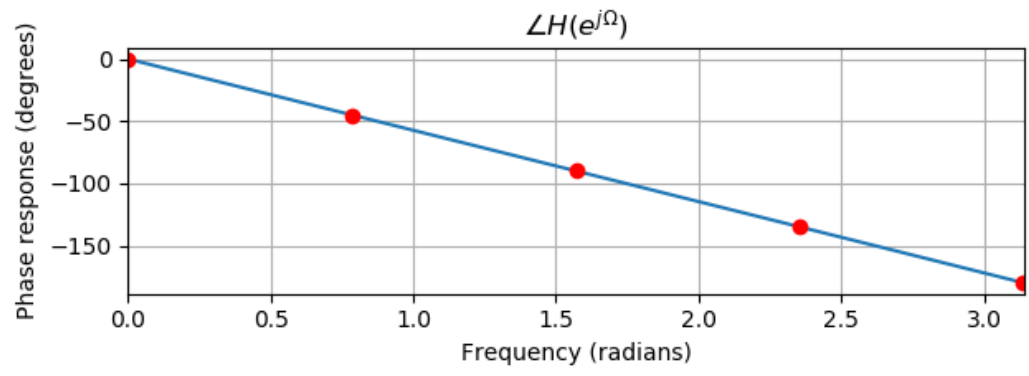
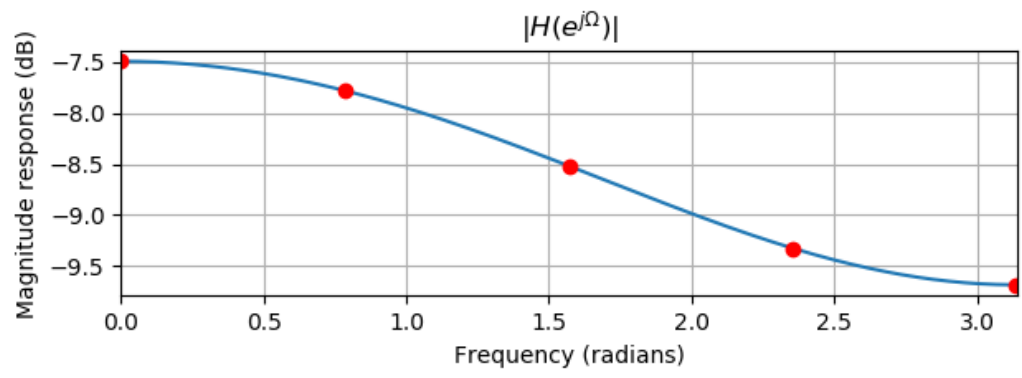

## Problem 7.2

Design a three-tap FIR high-pass filter with a cutoff frequency of 1600 Hz and a sampling rate of 8000 Hz using

2. Hamming window function.

Determine the transfer function and difference equation of the designed FIR system, and compute and plot the magnitude frequency response for  $\Omega=0, \pi/4, \pi/2, 3\pi/4$ , and  $\pi$  (rad).

### solution

$$2 \times M + 1 = 3 \Rightarrow M = 1$$

$$\Omega_c = 2\pi \times \frac{f_c}{f_s} = 1.2566$$

$h(-M) \sim h(M)$  are  $[-0.3027, 0.6, -0.3027]$

$$h(n) = \begin{cases} \frac{\pi - \Omega_c}{\pi} & \text{for } n = 0 \\ -\frac{\sin(\Omega_c n)}{n\pi} & \text{for } n \neq 0 \quad -M \leq n \leq M \end{cases}$$

2. Hamming window function.

$$h_w(n) = h(n) \cdot w(n) = [-0.0242, 0.6, -0.0242]$$

$$w_{\text{ham}}(n) = 0.54 + 0.46 \cos\left(\frac{n\pi}{M}\right), \quad -M \leq n \leq M$$

Transfer function

$$H(z) = -0.0242 + 0.6z^{-1} - 0.0242z^{-2}$$

Difference equation

$$y(n) = -0.0242x(n) + 0.6x(n-1) - 0.0242x(n-2)$$

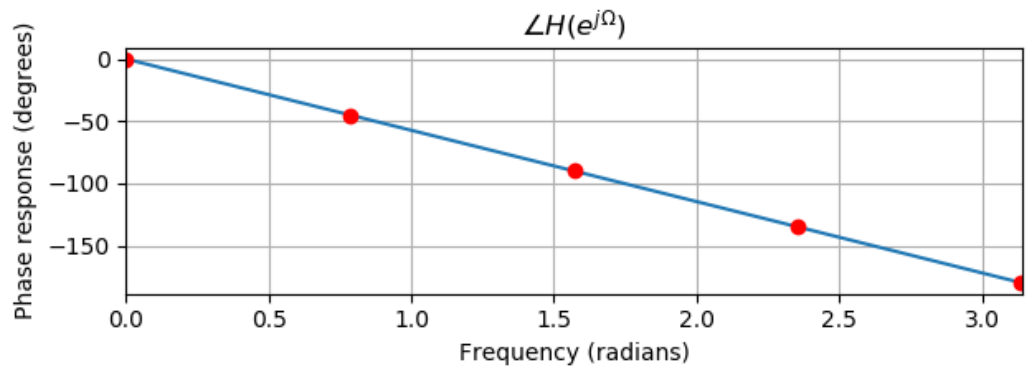
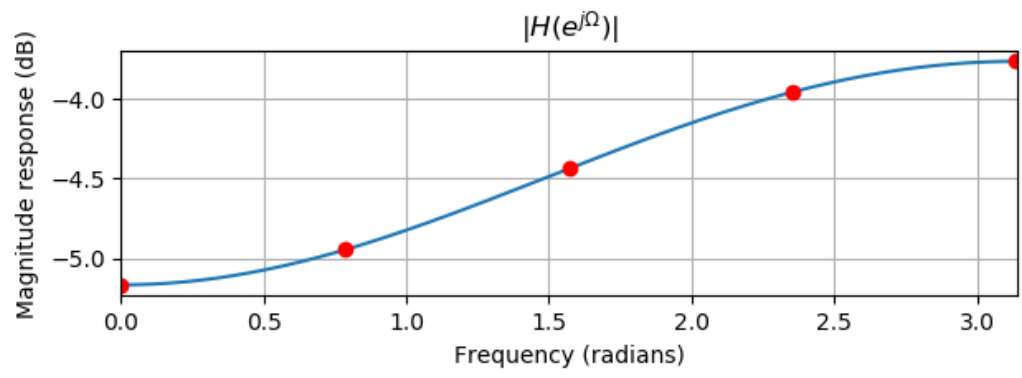

## Problem 7.5

Design a five-tap FIR bandpass filter with a lower cutoff frequency of 1600 Hz, an upper cutoff frequency of 1800 Hz, and a sampling rate of 8000 Hz using

2. Hamming window function.

Determine the transfer function and difference equation of the designed FIR system, and compute and plot the magnitude frequency response for  $\Omega=0, \pi/4, \pi/2, 3\pi/4$ , and  $\pi$  (rad).

### solution

$$2 \times M + 1 = 5 \Rightarrow M = 2$$

$$\Omega_c = 2\pi \times \frac{f_c}{f_s} = [1.2566, 1.4137] = [\Omega_L, \Omega_H]$$

$$h(n) = \begin{cases} \frac{\Omega_H - \Omega_L}{\pi} & \text{for } n = 0 \\ \frac{\sin(\Omega_H n)}{n\pi} - \frac{\sin(\Omega_L n)}{n\pi} & \text{for } n \neq 0 \end{cases} \quad -M \leq n \leq M$$

$$h(-M) \sim h(M) \text{ are } [-0.0444, 0.0117, 0.05, 0.0117, -0.0444]$$

2. Hamming window function.

$$w_{\text{ham}}(n) = 0.54 + 0.46 \cos\left(\frac{n\pi}{M}\right), \quad -M \leq n \leq M$$

$$h_w(n) = h(n) \cdot w(n) = [-0.0035, 0.0063, 0.05, 0.0063, -0.0035]$$

Transfer function

$$H(z) = -0.0035 + 0.0063z^{-1} + 0.05z^{-2} + 0.0063z^{-3} - 0.0035z^{-4}$$

Difference equation

$$y(n) = -0.0035x(n) + 0.0063x(n-1) + 0.05x(n-2) + 0.0063x(n-3) - 0.0035x(n-4)$$

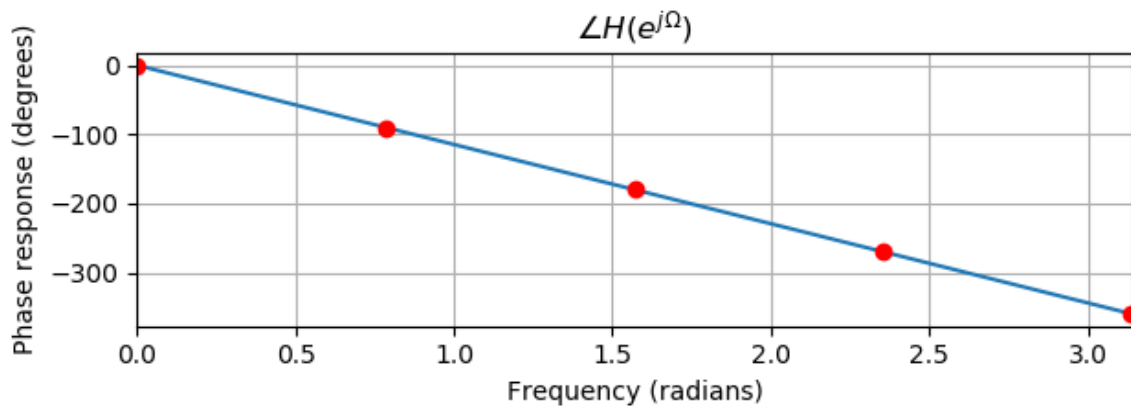
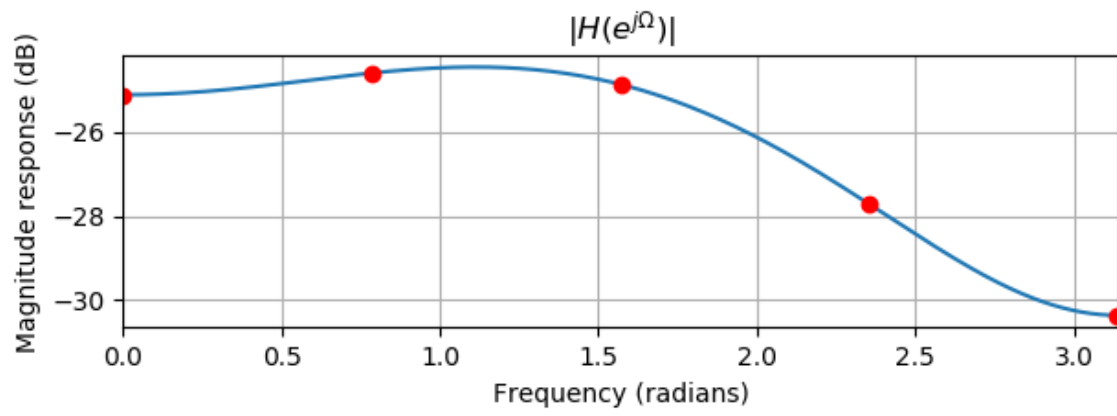

## Problem 7.6

Design a five-tap FIR band-reject filter with a lower cutoff frequency of 1600 Hz, an upper cutoff

frequency of 1800 Hz, and a sampling rate of 8000 Hz using

2. Hamming window function.

Determine the transfer function and difference equation of the designed FIR system, and compute and plot the magnitude frequency response for  $\Omega=0, \pi/4, \pi/2, 3\pi/4$ , and  $\pi$  (rad).

### solution

$$2 \times M + 1 = 5 \Rightarrow M = 2$$

$$\Omega_c = 2\pi \times \frac{f_c}{f_s} = [1.2566, 1.4137] = [\Omega_L, \Omega_H]$$

$$h(n) = \begin{cases} \frac{\pi - \Omega_H + \Omega_L}{\pi} & \text{for } n = 0 \\ -\frac{\sin(\Omega_H n)}{n\pi} + \frac{\sin(\Omega_L n)}{n\pi} & \text{for } n \neq 0 \quad -M \leq n \leq M \end{cases}$$

$$h(-M) \sim h(M) \text{ are } [0.0444, -0.0117, 0.95, -0.0117, 0.0444]$$

2. Hamming window function.

$$w_{\text{ham}}(n) = 0.54 + 0.46 \cos\left(\frac{n\pi}{M}\right), -M \leq n \leq M$$

$$h_w(n) = h(n) \cdot w(n) = [0.0035, -0.0063, 0.95, -0.0063, 0.0035]$$

Transfer function

$$H(z) = 0.0035 - 0.0063z^{-1} + 0.95z^{-2} - 0.0063z^{-3} + 0.0035$$

Difference equation

$$y(n) = 0.0035x(n) - 0.0063x(n-1) + 0.95x(n-2) - 0.0063x(n-3) + 0.0035x(n)$$



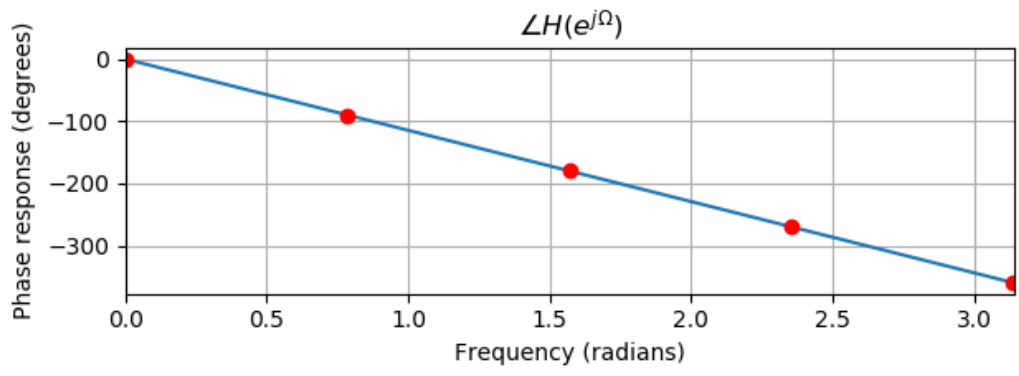
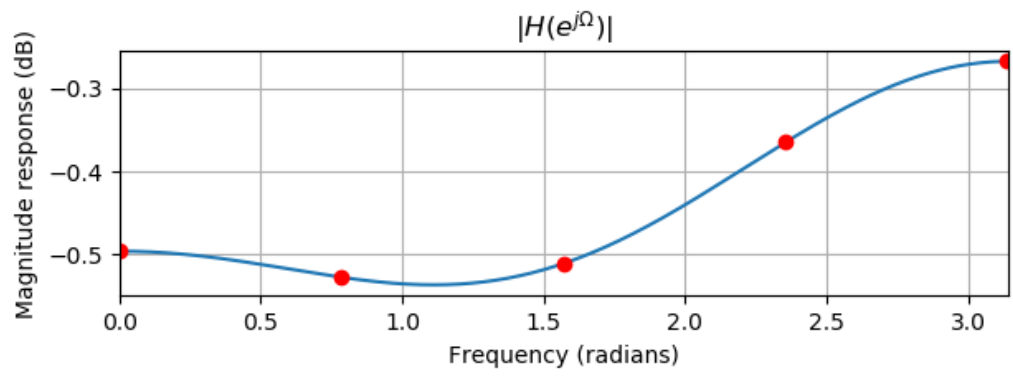

## Problem 7.7

Given an FIR lowpass filter design with the following specifications:

- Passband=0~800 Hz
- Stopband=1200~4000 Hz
- Passband ripple=0.1 dB
- Stopband attenuation=40 dB
- Sampling rate=8000 Hz

Determine the following:

1. Window method
2. Length of the FIR filter
3. Cutoff frequency for the design equation

### solution

Look up **Table 7.7** in page 254, based on the requirements:

- Passband ripple
- Stopband attenuation

1. Window method: **Hanning**
2. Compute the transition band

$$\Delta f = \frac{|f_{pass} - f_{stop}|}{f_s} = (1200 - 800)/8000$$

Then use formula in **Table 7.7**

$$N = \frac{3.1}{\Delta f} = 62$$

Find the closest odd number **63**

3. Then estimate the cutoff frequency

$$f_c = (f_{pass} + f_{stop})/2 = (800 + 1200)/2$$

The cutoff frequency are 1000 Hz

## Problem 7.8

Given an FIR high-pass filter design with the following specifications:

- Stopband=0~1500 Hz
- Passband=2000~4000 Hz
- Passband ripple=0.02 dB
- Stopband attenuation=60 dB
- Sampling rate=8000 Hz

Determine the following:

1. Window method
2. Length of the FIR filter
3. Cutoff frequency for the design equation.

### solution

Look up **Table 7.7** in page 254, based on the requirements:

- Passband ripple
- Stopband attenuation

1. Window method: **Blackman**
2. Compute the transition band

$$\Delta f = \frac{|f_{pass} - f_{stop}|}{f_s} = (2000 - 1500)/8000$$

Then use formula in **Table 7.7**

$$N = \frac{5.5}{\Delta f} = 88$$

Find the closest odd number **89**

3. Then estimate the cutoff frequency

$$f_c = (f_{pass} + f_{stop})/2 = (2000 + 1500)/2$$

The cutoff frequency are 1750 Hz

## Problem 7.9

Given an FIR bandpass filter design with the following specifications:

- Lower cutoff frequency=1500 Hz
- Lower transition width=600 Hz
- Upper cutoff frequency=2300 Hz
- Upper transition width=600 Hz
- Passband ripple=0.1 dB
- Stopband attenuation=50 dB
- Sampling rate=8000 Hz

Determine the following:

1. Window method
2. Length of the FIR filter
3. Cutoff frequencies for the design equation

### solution

Look up **Table 7.7** in page 254, based on the requirements:

- Passband ripple
- Stopband attenuation

1. Window method: **Hamming**
2. Compute the transition band

$$\Delta f = \frac{|f_{pass} - f_{stop}|}{f_s} = 600/8000$$

Then use formula in **Table 7.7**

$$N = \frac{3.3}{\Delta f} = 44$$

Find the closest odd number **45**

3. Then estimate the cutoff frequency

$$f_c = (f_{pass} + f_{stop})/2$$

The cutoff frequency are 1500, 2300 Hz

$$f_{pass-1} = 1800, f_{stop-1} = 1200\text{Hz}$$

$$f_{pass-2} = 2000, f_{stop-2} = 2600\text{Hz}$$

## Problem 7.10

Given an FIR band-stop filter design with the following specifications:

- Lower passband=0~1200 Hz
- Stopband=1600~2000 Hz
- Upper passband=2400~4000 Hz
- Passband ripple=0.05 dB
- Stopband attenuation=60 dB
- Sampling rate=8000 Hz

Determine the following:

1. Window method
2. Length of the FIR filter
3. Cutoff frequencies for the design equation

### solution

Look up **Table 7.7** in page 254, based on the requirements:

- Passband ripple
- Stopband attenuation

1. Window method: **Blackman**
2. Compute the transition band

$$\Delta f = \frac{|f_{pass} - f_{stop}|}{f_s} = (1600 - 1200)/8000 = (2400 - 2000)/8000$$

Then use formula in **Table 7.7**

$$N = \frac{5.5}{\Delta f} = 110$$

Find the closest odd number **111**

3. Then estimate the cutoff frequency

$$f_c = (f_{pass} + f_{stop})/2$$

The cutoff frequency are 1400, 2200 Hz

## Problem 7.11

Given an FIR system

$$H(z) = 0.25 - 0.5z^{-1} + 0.25z^{-2}$$

realize  $H(z)$  using each of the following specified methods:

1. Transversal form, and write the difference equation for implementation
2. Linear phase form, and write the difference equation for implementation

### solution

1. Transversal form

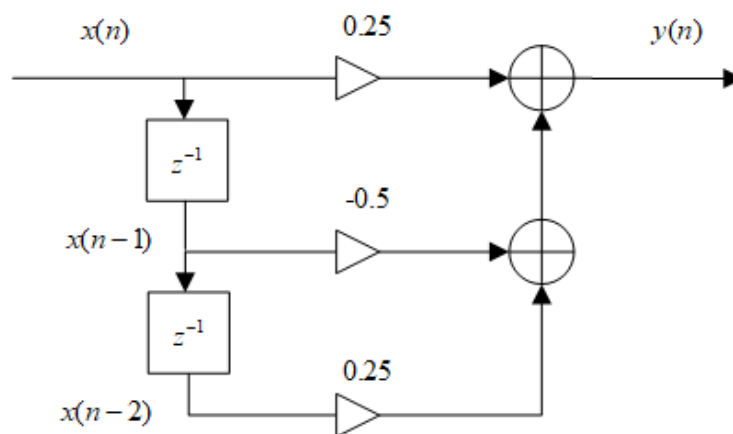

difference equation for implementation

$$y(n) = 0.25x(n) - 0.5x(n-1) + 0.25x(n-2)$$

2. Linear phase form

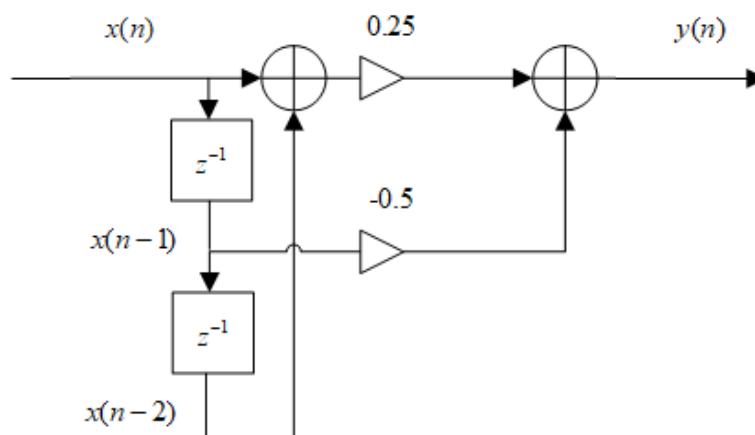

difference equation for implementation

$$y(n) = 0.25[x(n) + x(n-2)] - 0.5x(n-1)$$

## Problem 7.15

Determine the transfer function for a five-tap FIR lowpass filter with a cutoff frequency of 2000 Hz and a sampling rate of 8000 Hz using the frequency sampling method.

### solution

$$N = 2 \times M + 1 \Rightarrow M = 2$$

To reduce this ripple effect, the modified specification with a smooth transition band

$$H_k = [1, 0.5, 0] \text{ for } k=0 \sim M$$

Then we can calculate  $h(-M), \dots, h(0), \dots, h(M)$

$$b_{n+M} = h(n) = \frac{1}{2M+1} \left\{ H_0 + 2 \sum_{k=1}^M H_k \cos \left( \frac{2\pi kn}{2M+1} \right) \right\} \text{ for } n = -M, \dots, 0, \dots, M$$

Thus,  $h(-M) \sim h(M)$  are  $[0.0382, 0.2618, 0.4, 0.2618, 0.0382]$

The transfer function  $H(z) = 0.0382 + 0.2618z^{-1} + 0.4z^{-2} + 0.2618z^{-3} + 0.0382z^{-4}$

If we don't consider the ripple effect:

$$H_k = [1, 1, 0] \text{ for } k=0 \sim M$$

Thus,  $h(-M) \sim h(M)$  are  $[-0.1236, 0.3236, 0.6, 0.3236, -0.1236]$

The transfer function

$$H(z) = -0.1236 + 0.3236z^{-1} + 0.6z^{-2} + 0.3236z^{-3} - 0.1236z^{-4}$$

## Problem 7.19

A lowpass FIR filter to be designed has the following specifications:

Design method: Parks-McClellan algorithm

- Sampling rate=1000 Hz
- Passband=0~200 Hz
- Stopband=300~500 Hz
- Passband ripple=1 dB
- Stopband attenuation=40 dB

Determine the error weights  $W_p$  and  $W_s$  for passband and stopband in the Parks-McClellan algorithm.

### solution

Map  $f \rightarrow \Omega$

$$\Omega = 2\pi \frac{f}{f_s}$$
$$[0, 0.4, 0.6, 1] \leftarrow [0, 200, 300, 500]$$

Thus  $\Omega = [0, 0.4, 0.6, 1]$ , now determine the error weights  $W_p$  and  $W_s$

$$\delta_p = 10^{\left(\frac{1}{20}\right)} - 1 = 0.1220$$

$$\delta_s = 10^{\left(\frac{-40}{20}\right)} = 0.01$$

$$\frac{\delta_p}{\delta_s} = 12.2 \approx \frac{12}{1} = \frac{W_s}{W_p}$$

$$W_s = 12 \text{ and } W_p = 1$$

So,  $W_s = 12$  and  $W_p = 1$ ; Set minimal Filter order = 12

```
% Problem 7.19
clear; clc; close all
fs = 1000;
f = [ 0 0.4 0.6 1]; % edge frequencies
m = [ 1 1 0 0] ; % ideal magnitudes
w = [ 1 12 ]; % error weight factors [W_pass, W_stop]
b = firpm(12, f, m, w); % (12+1)Parks-McClellan algorithm and Remez
exchange
format long
vpa(b, 4)
freqz(b, 1, 512, fs) % plot the frequency response
axis([0 fs/2 -80 10]);
```



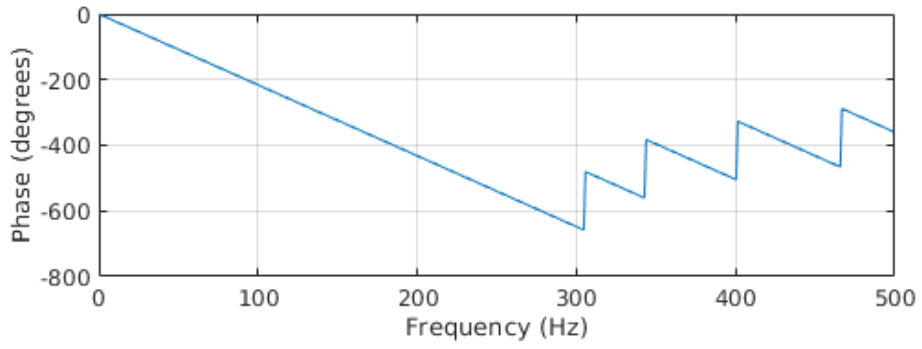
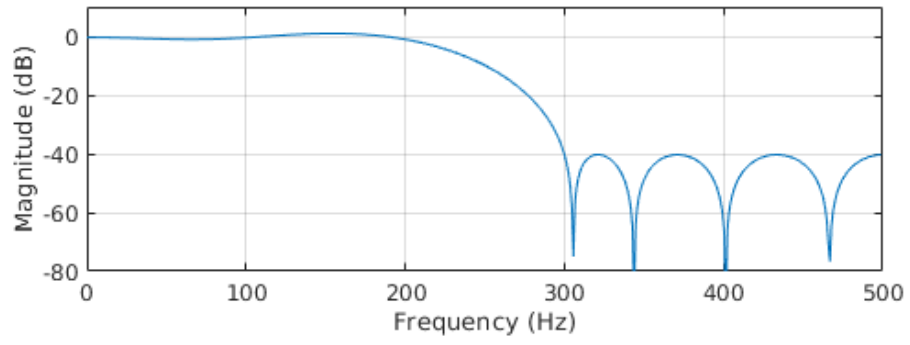

KEY	VALUE	KEY	VALUE
$b_0 = b_{12}$	0.03034	$b_1 = b_{11}$	0.04032
$b_2 = b_{10}$	-0.03153	$b_3 = b_9$	-0.1051
$b_4 = b_8$	0.01087	$b_5 = b_7$	0.3023
$b_6$	0.4654		

## Problem 7.20

A bandpass FIR filter to be designed has the following specifications:

Design method: Parks-McClellan algorithm

- Sampling rate=1000 Hz
- Passband=200~250 Hz
- Lower stopband=0~150 Hz
- Upper stopband=300~500 Hz
- Passband ripple=1 dB
- Stopband attenuation=30 dB

Determine the error weights  $W_p$  and  $W_s$  for passband and stopband in the Parks-McClellan algorithm

### solution

Map  $f \rightarrow \Omega$

$$\Omega = 2\pi \frac{f}{f_s}$$

$$[0, 0.3, 0.4, 0.5, 0.6, 1] \leftarrow [0, 150, 200, 250, 300, 500]$$

Thus  $\Omega = [0, 0.3, 0.4, 0.5, 0.6, 1]$ , now determine the error weights  $W_p$  and  $W_s$

$$\delta_p = 10^{\left(\frac{1}{20}\right)} - 1 = 0.1220$$

$$\delta_s = 10^{\left(\frac{-30}{20}\right)} = 0.0316$$

$$\frac{\delta_p}{\delta_s} = 3.86 \approx \frac{39}{10} = \frac{W_s}{W_p}$$

$$W_s = 39 \text{ and } W_p = 10$$

So,  $W_s = 39$  and  $W_p = 10$ ; Set minimal Filter order = **18**

```

% Problem 7.20
clear; clc; close all
fs = 1000;
f = [ 0, 0.3, 0.4, 0.5, 0.6, 1]; % edge frequencies
m = [ 0 0 1 1 0 0]; % ideal magnitudes
w = [ 39 10 39 ]; % error weight factors [W_stop, W_pass, W_stop]
b = firpm(18, f, m, w); % (18+1) taps Parks-McClellan algorithm and
Remez exchange
format long
vpa(b, 4)
freqz(b, 1, 512, fs); % plot the frequency response
axis([0 fs/2 -80 10])

```

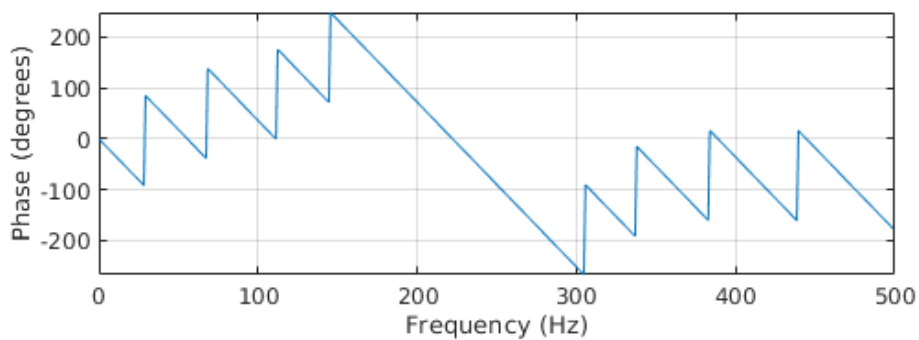
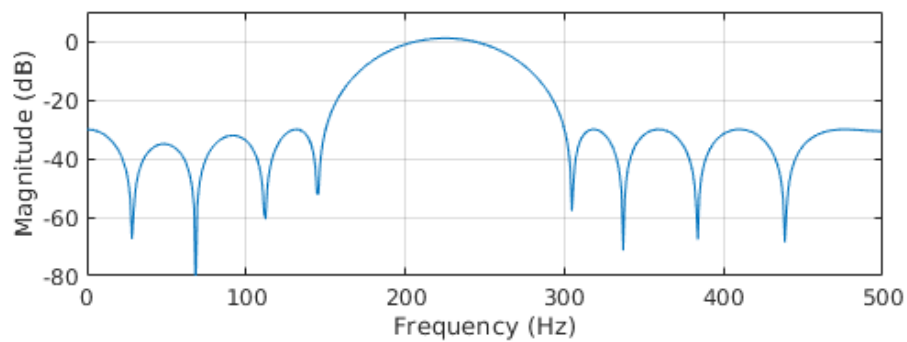

KEY	VALUE	KEY	VALUE
$b_0 = b_{18}$	0.0329	$b_1 = b_{17}$	0.01892
$b_2 = b_{16}$	-0.06725	$b_3 = b_{15}$	-0.05156
$b_4 = b_{14}$	0.08012	$b_5 = b_{13}$	0.1148
$b_6 = b_{12}$	-0.07239	$b_7 = b_{11}$	-0.1604
$b_8 = b_{10}$	0.02714	$b_9$	0.1867

## Advanced Problems

### Problem 7.38

The frequency response of a half-band digital differentiator is given below:

$$H(e^{j\Omega}) = j\Omega \text{ for } |\Omega| < \pi/2:$$

Design the FIR differentiator with  $(2M+1)$  coefficients using the Fourier transform method

### solution

Using the Fourier transform design method, we can obtain the filter coefficients below:

$$\begin{aligned} h(n) &= \frac{1}{2\pi} \int_{-\pi/2}^{\pi/2} H(e^{j\Omega}) e^{jn\Omega} d\Omega \\ &= \frac{1}{2\pi} \int_{-\pi/2}^{\pi/2} j\Omega e^{jn\Omega} d\Omega \\ &= \frac{1}{2\pi} \int_{-\pi/2}^{\pi/2} \frac{\partial[e^{jn\Omega}]}{\partial n} d\Omega \\ &= \frac{1}{2\pi} \frac{d}{dn} \int_{-\pi/2}^{\pi/2} [e^{jn\Omega}] d\Omega \\ &= \frac{1}{2\pi} \frac{d}{dn} \left[ \frac{2 \sin(\frac{\pi}{2}n)}{n} \right] \quad \left\{ \text{define } \left[ \frac{2 \sin(\frac{\pi}{2}n)}{n} \right] \Big|_{n=0} = \pi \right\} \\ &= \begin{cases} \frac{1}{2\pi} \frac{2 \cos(\frac{\pi}{2}n) \frac{\pi}{2}n - 2 \sin(\frac{\pi}{2}n)}{n^2} & n \neq 0 \\ 0 & n = 0 \end{cases} \\ &= \begin{cases} \frac{\cos(\frac{\pi}{2}n)}{2n} - \frac{\sin(\frac{\pi}{2}n)}{\pi n^2} & n \neq 0 \\ 0 & n = 0 \end{cases} \end{aligned}$$

The  $h(n)$  is an odd function,  $h(-n) = -h(n)$ :

Converting non-causal half-band differentiator to causal one with  $(2M+1)$  coefficients yields the following relation:

$$b_n = \begin{cases} -h(M-n) & n = 0, 1, 2, \dots, M-1 \\ 0 & n = M \\ h(n-M) & n = M+1, \dots, 2M \end{cases}$$

# MATLAB Projects

## Problem 7.36

Speech enhancement:

A digitally recorded speech in the noisy environment can be enhanced using a lowpass filter if the recorded speech with a sampling rate of 8000 Hz contains information within 1600 Hz.

Design a lowpass filter to remove the high-frequency noise above 1600 Hz with following filter specifications:

- passband frequency range: 0~1600 Hz;
- passband ripple: 0.02 dB;
- stop-band frequency range: 1800~4000 Hz;
- stop-band attenuation: 50 dB.

Use the designed low-pass filter to filter the noisy speech and adopt the following code to simulate the noisy speech:

```
load speech.dat
t=[0:length(speech)-1]*T;
th=mean(speech,speech)/4; %Noise power =(1/4) speech power
noise=sqrt(th)*randn([1,length(speech)]); %Generate Gaussian noise
nspeech=speech+noise; % Generate noisy speech
```

In this project, plot the speech samples and spectra for both noisy speech and the enhanced speech and use MATLAB sound() function to evaluate the sound qualities. For example, to hear the noisy speech:

```
sound(nspeech / max(abs(nspeech)), 8000);
```

## solution

Look up **Table 7.7** in page 254, based on the requirements:

- Passband ripple: 0.02 dB;
- Stop-band attenuation: 50 dB.

1. Window method: **Hamming**
2. Compute the transition band

$$\Delta f = \frac{|f_{pass} - f_{stop}|}{f_s} = (1800 - 1600)/8000$$

Then use formula in **Table 7.7**

$$N = \frac{3.3}{\Delta f} = 132$$

Find the closest odd number **133**

3. Then estimate the cutoff frequency

$$f_c = (f_{pass} + f_{stop})/2$$

The cutoff frequency are **1700 Hz**

$$4. 2 \times M + 1 = 133 \Rightarrow M = 66$$

$$\Omega_c = 2\pi \times \frac{f_c}{f_s} = 1.3352$$

$$h(n) = \begin{cases} \frac{\Omega_c}{\pi} & \text{for } n = 0 \\ \frac{\sin(\Omega_c n)}{n\pi} & \text{for } n \neq 0 \end{cases} \quad -M \leq n \leq M$$

$h(-M) \rightarrow h(M)$  are

```
[0.000754, -0.004524, -0.002923, 0.003281, 0.004574,
-0.001218, -0.005305, -0.001259, 0.00489, 0.003627, -0.003341,
-0.005347, 0.000922, 0.005987, 0.001892, -0.005322, -0.004502,
0.003394, 0.006307, -0.000531, -0.006835, -0.002707, 0.005853,
0.005629, -0.003441, -0.007549, -0.0, 0.007936, 0.003803,
-0.006542, -0.007153, 0.00348, 0.009247, 0.000757, -0.00946,
-0.005365, 0.007503, 0.009359, -0.003513, -0.011753,
-0.001915, 0.011763, 0.007796, -0.008988, -0.012892, 0.003538,
0.015915, 0.003911, -0.015756, -0.01216, 0.011694, 0.019605,
-0.003557, -0.02441, -0.008197, 0.024673, 0.022508, -0.01848,
-0.037841, 0.003568, 0.052398, 0.024362, -0.06438, -0.080682,
0.072255, 0.309515, 0.425, 0.309515, 0.072255, -0.080682,
-0.06438, 0.024362, 0.052398, 0.003568, -0.037841, -0.01848,
0.022508, 0.024673, -0.008197, -0.02441, -0.003557, 0.019605,
0.011694, -0.01216, -0.015756, 0.003911, 0.015915, 0.003538,
-0.012892, -0.008988, 0.007796, 0.011763, -0.001915,
-0.011753, -0.003513, 0.009359, 0.007503, -0.005365, -0.00946,
0.000757, 0.009247, 0.00348, -0.007153, -0.006542, 0.003803,
0.007936, -0.0, -0.007549, -0.003441, 0.005629, 0.005853,
-0.002707, -0.006835, -0.000531, 0.006307, 0.003394,
-0.004502, -0.005322, 0.001892, 0.005987, 0.000922, -0.005347,
-0.003341, 0.003627, 0.00489, -0.001259, -0.005305, -0.001218,
0.004574, 0.003281, -0.002923, -0.004524, 0.000754]
```

5. Hamming window function

$$w_{\text{ham}}(n) = 0.54 + 0.46 \cos\left(\frac{n\pi}{M}\right), -M \leq n \leq M$$

$$h_w(n) = h(n) \cdot w(n) \text{ are}$$

```
[6e-05, -0.000364, -0.00024, 0.000278, 0.000404, -0.000113,
-0.000523, -0.000133, 0.000552, 0.000441, -0.000438,
-0.000757, 0.000141, 0.00099, 0.000337, -0.001024, -0.000932,
0.000755, 0.001506, -0.000136, -0.001867, -0.000789, 0.001814,
0.001853, -0.0012, -0.002786, -0.0, 0.003257, 0.001641,
-0.002963, -0.003394, 0.001727, 0.004791, 0.000409, -0.005316,
-0.003132, 0.004543, 0.005868, -0.002278, -0.00787, -0.001322,
0.008363, 0.005699, -0.006748, -0.009927, 0.002791, 0.012841,
0.003224, -0.013255, -0.010427, 0.010208, 0.017403, -0.003207,
-0.022328, -0.007598, 0.023153, 0.021357, -0.017711,
-0.036594, 0.003477, 0.051422, 0.024046, -0.063844, -0.080304,
0.072104, 0.309354, 0.425, 0.309354, 0.072104, -0.080304,
-0.063844, 0.024046, 0.051422, 0.003477, -0.036594, -0.017711,
0.021357, 0.023153, -0.007598, -0.022328, -0.003207, 0.017403,
0.010208, -0.010427, -0.013255, 0.003224, 0.012841, 0.002791,
-0.009927, -0.006748, 0.005699, 0.008363, -0.001322, -0.00787,
-0.002278, 0.005868, 0.004543, -0.003132, -0.005316, 0.000409,
0.004791, 0.001727, -0.003394, -0.002963, 0.001641, 0.003257,
-0.0, -0.002786, -0.0012, 0.001853, 0.001814, -0.000789,
-0.001867, -0.000136, 0.001506, 0.000755, -0.000932,
-0.001024, 0.000337, 0.00099, 0.000141, -0.000757, -0.000438,
0.000441, 0.000552, -0.000133, -0.000523, -0.000113, 0.000404,
0.000278, -0.00024, -0.000364, 6e-05]
```

The magnitude and phase of  $H(e^{j\Omega})$  are

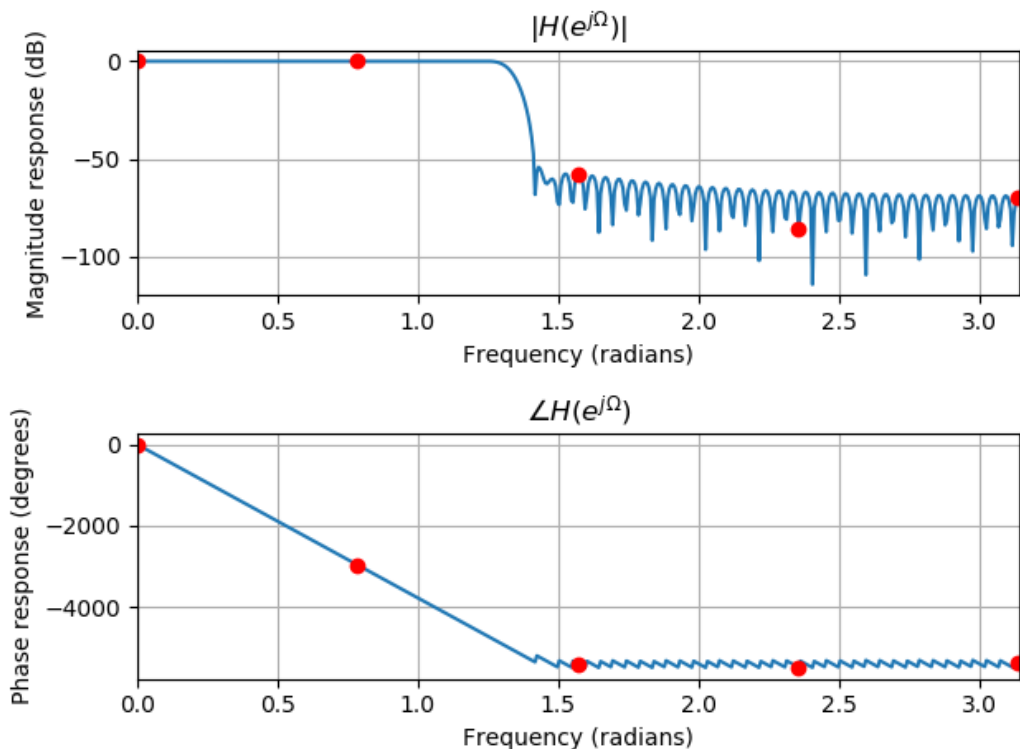

6. Speech with noise:

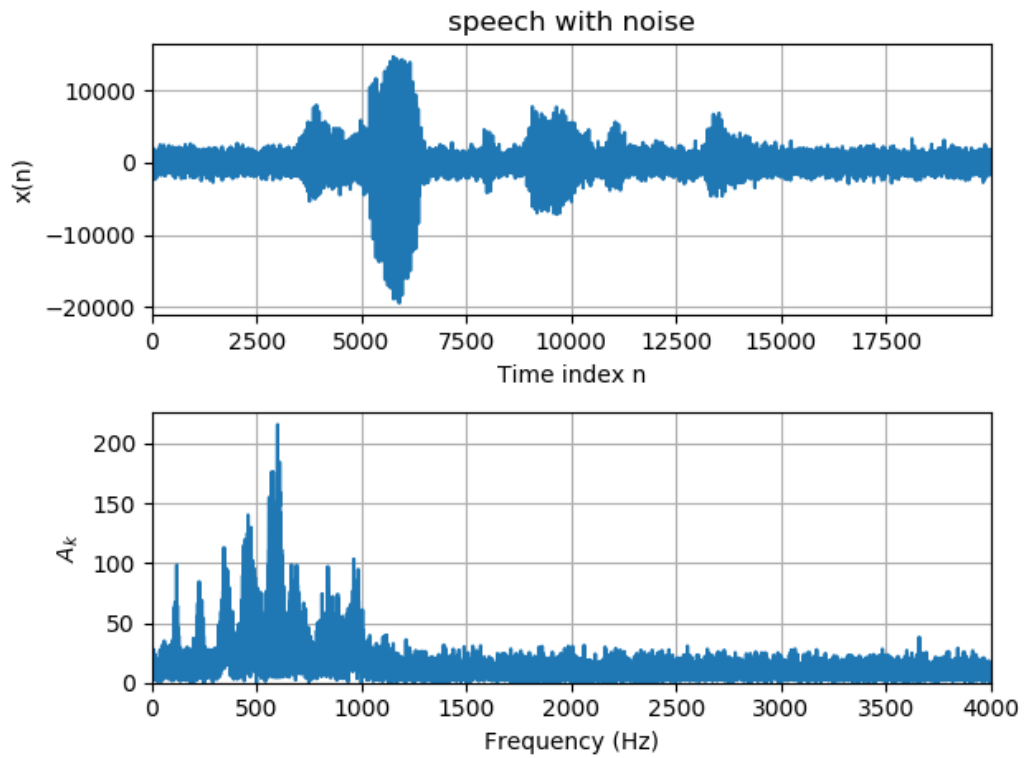

Speech filtered:

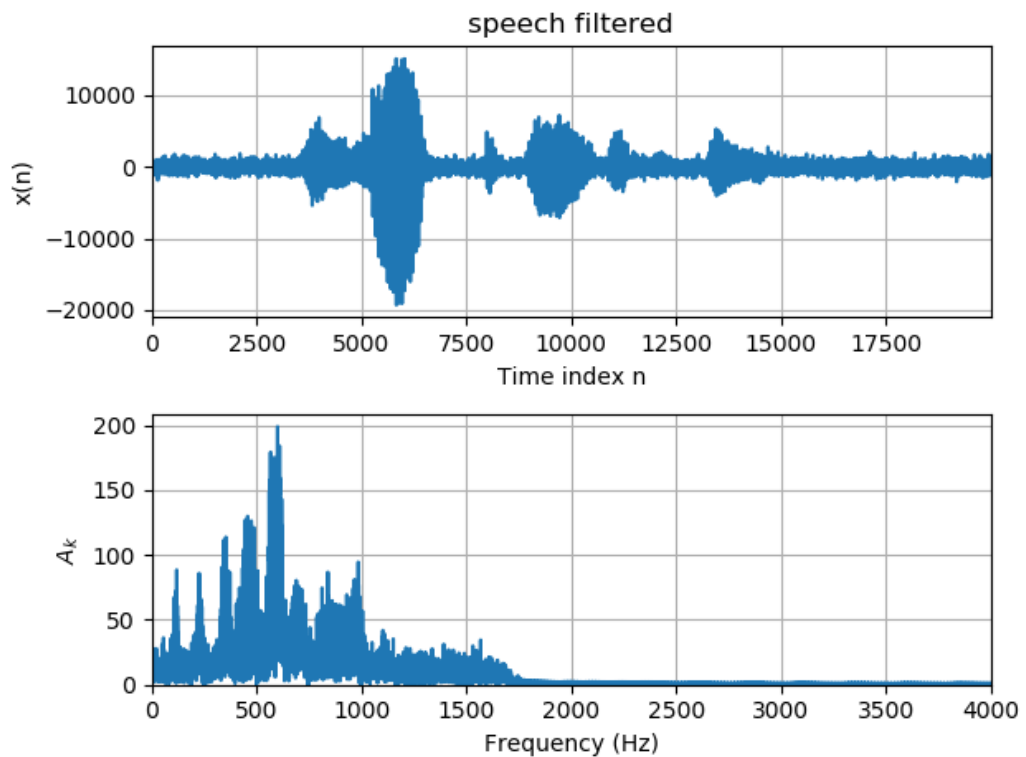

### comment

1. The low-pass filter eliminates the high-frequency component of noise.
2. The quality of speech improves
3. The results and figures (except Problem 7.19, 7.20) are generated by **Python** scripts

I used the python library written on my own to replace the function in MATLAB.



Here is the main script for problem 7.36

```
from fir_filter.choose_window_type import *
from fir_filter.calc_window_len import *
from fir_filter.calc_freq_cutoff import *
from fir_filter.fir_filter import *
from fir_filter.window import *
from fir_filter.calc_mag_angle import *
from fir_filter.filter import *
from fir_filter.fftltd import *

# choose window type
passband_ripple = 0.02
stopband_attenuation = 50
str_window_type = choose_window_type(passband_ripple,
stopband_attenuation)
print(str_window_type)
# calc length of window
f_s = 8000
list_transient_band = [ [1600, 1800] ]
window_len = calc_window_len(str_window_type,
list_transient_band, f_sample=f_s)
print(window_len)
# calc the cutoff frequency & normalized cutoff frequency
list_freq_cutoff = calc_freq_cutoff(list_transient_band)
print(list_freq_cutoff)
print_approx([calc_omega(list_freq_cutoff[0], f_s)])
# calc  $h(-M) \sim h(M)$  list of filter
list_filter = fir_filter(list_freq_cutoff, f_s, window_len,
"low_pass")
print_approx(list_filter, precision=6)
# Hamming window: calc  $h_w(n) = h(n) * w(n)$ 
str_window_type = "Hamming"
path_fig = "../p7_36_hamm.png"
list_filter_window = window(list_filter,
str_window_type=str_window_type)
print_approx(list_filter_window, precision=6)
# plot Magnitude & Phase of  $H(e^{j \Omega})$ 
list_mag, list_angle, list_omega =
calc_mag_angle(list_filter_window)
plot_mag_angle(list_mag, list_angle, list_omega,
path_fig=path_fig)
# read data: "speech.dat"
import numpy as np
filename = "./speech.dat"
speech = np.loadtxt(filename)
```

```
th = np.mean( speech**2 ) / 4 # Noise power =(1/4) speech
power
noise = np.sqrt(th) * np.random.randn( len(speech) ) #
Generate Gaussian noise
nspeech = speech + noise # Generate noisy speech
# low-pass filter to filter the noisy speech
nspeech_filtered = filter(nspeech, list_filter_window)
nspeech_filtered = np.asarray(nspeech_filtered)
# save sounds
from scipy.io.wavfile import write
write("../nspeech.wav", f_s, nspeech)
write("../nspeech_filtered.wav", f_s, nspeech_filtered)
# plot speech with noise & filtered speech
plot_spectrum(nspeech, f_s, path_fig="../p7_36_noise.png",
str_title="speech with noise")
plot_spectrum(nspeech_filtered, f_s,
path_fig="../p7_36_filtered.png", str_title="speech filtered")
```